



**Progetto
Econdominium:**

BROCHURE 26

**CITONET:
CENTRUM**

**Servizi
ai condominii**

Work in progress

Brochure interna



CENTRUM

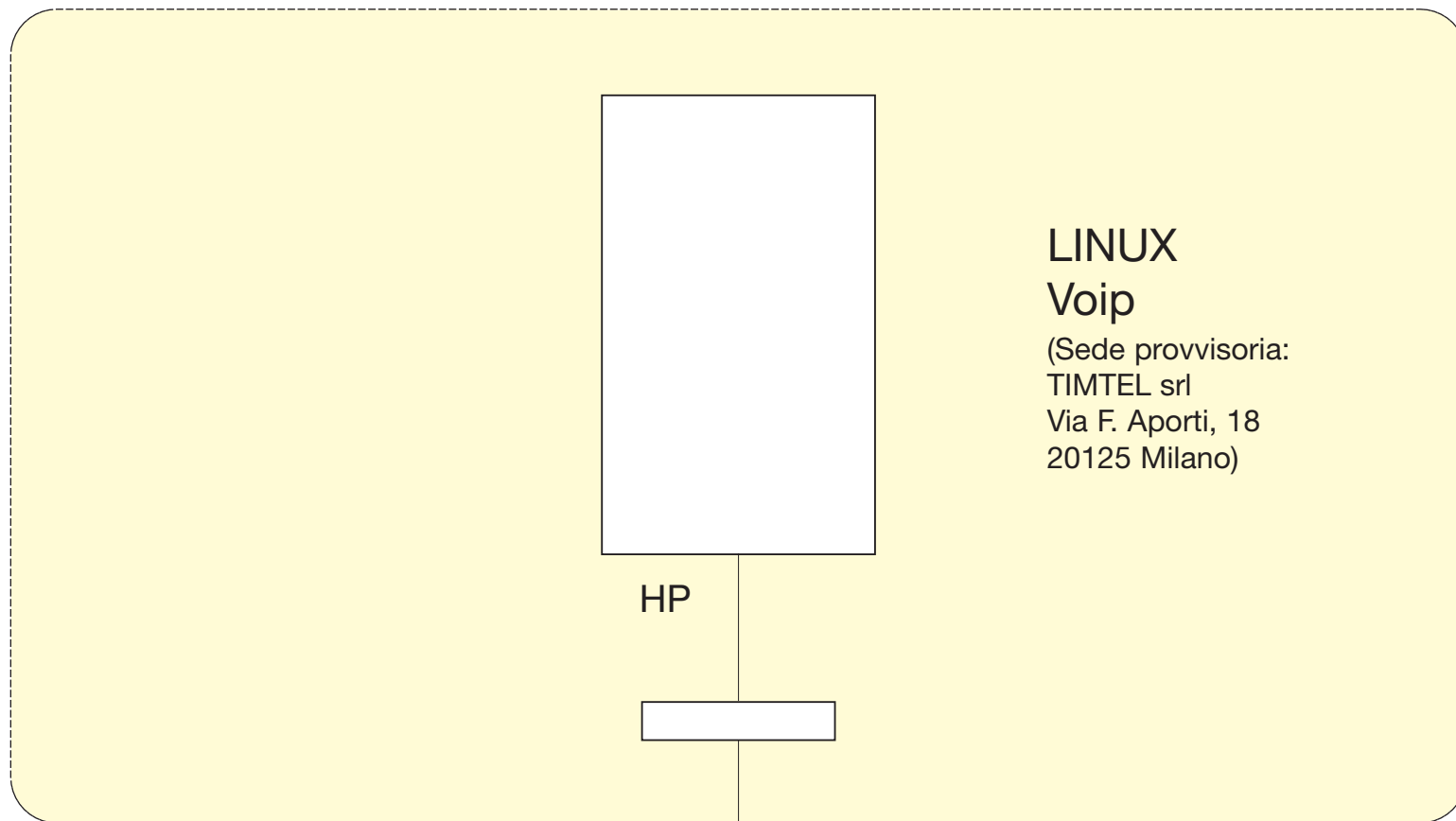

Centro Servizi Citoip



Progetto
Econdominium:

BROCHURE 26

CITONET:
CENTRUM

Servizi
ai condominii

Work in progress

Brochure interna

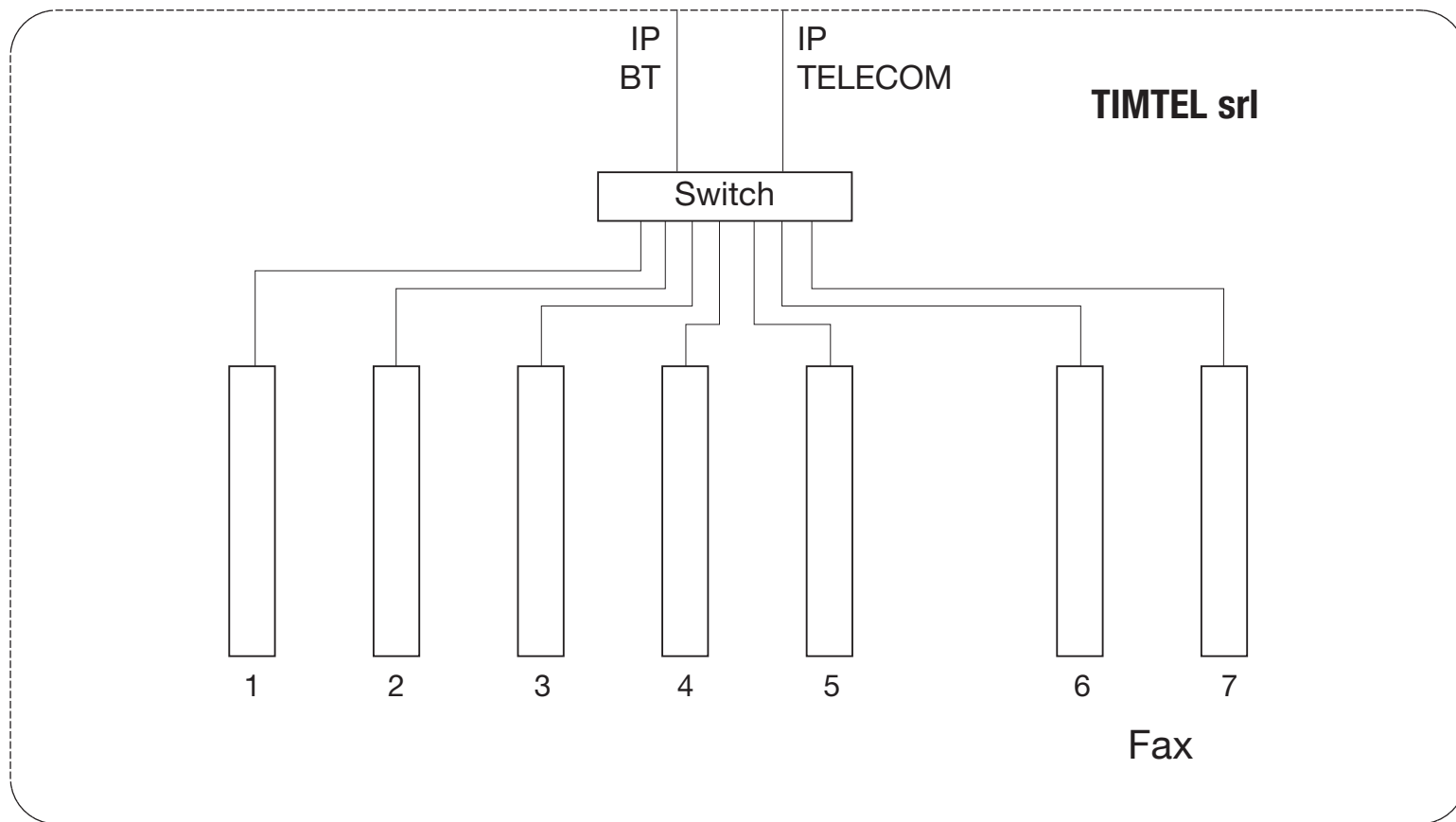

Centralino TIMTEL

TIMTEL
"TIMTELEIMPIANTI"

**Progetto
Econdominium:**

BROCHURE 26

**CITONET:
CENTRUM**

**Servizi
ai condomini**

Work in progress

Brochure interna

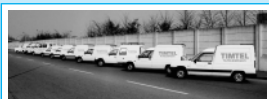

(1) Una chiamata al centralino Timtel (02 669 00 99) va al centralino HP, che lo switcha a un numero libero dei (1,2,3,4,5) di pag. 2.
Se però ha ricevuto istruzione, la chiamata torna in Internet verso un numero (Skype) interno, esempio Orsini al proprio cellulare (indicato come "SKYPE Ors" nell'esempio).

(1) 02 669 00 99

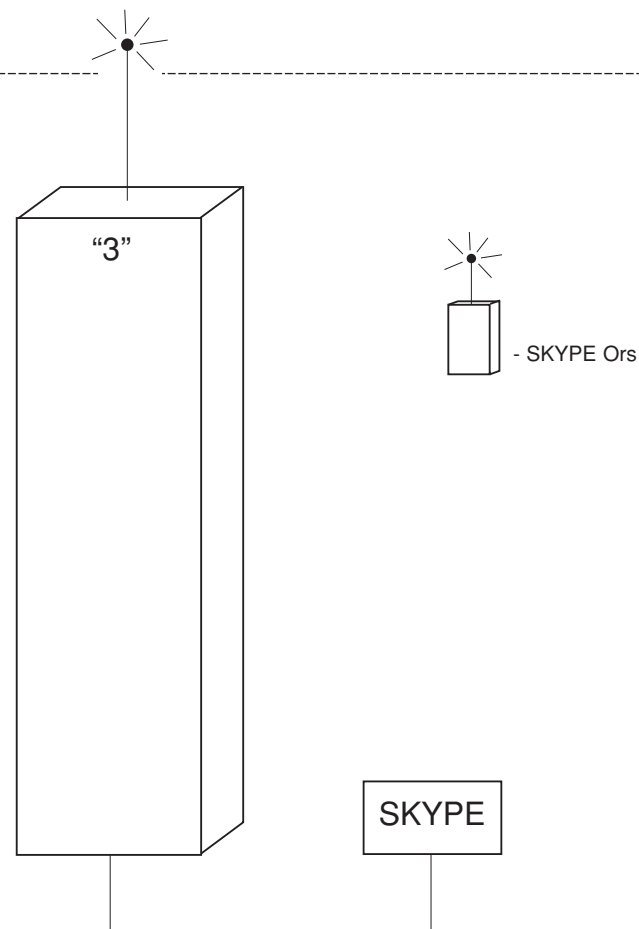
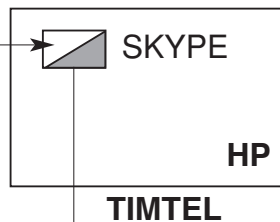



**Progetto
Econdominium:**

BROCHURE 26

**CITONET:
CENTRUM**

**Servizi
ai condominii**

Work in progress

Brochure interna

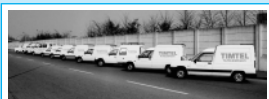

Schema generale

